

eureka

Owner's Guide

Thank you for purchasing your new eureka machine! Please read this Owner's Guide carefully before operating, and keep it properly.



Smart floor machine

FC9 Limited



CONTENTS

RECAUTIONS	3
ABOUT THE SCOPE OF USE OF THE PRODUCT	4
PRODUCT INTRODUCTION	5
FUNCTIONS	6
CLEANING AND MAINTENANCE	12
ANALYSIS AND SOLUTION OF COMMON PROBLEMS	14
TECHNICAL PARAMETER	15
CHINA ROHS	15
WARRANTY INFORMATION	16
WARRANTY CARD	17

RECAUTIONS

Before using the product, please read this manual carefully and completely, and install the machine in accordance with the procedures described in it. Please keep this manual properly. If you want to transfer the product to a third party for use, please include this manual. Any operation inconsistent with the instructions in this manual may cause product damage or serious personal injury. This product is only suitable for use in normal home environment, and not suitable for use in industry or outdoor environment. The product is not suitable for use by persons with physical, sensory or intellectual disabilities or persons lacking experience and common sense (including children), unless they are supervised or instructed by others to ensure safety.

- This product is suitable for hard floor in indoor home environment, including waxed floor, stone floor, rubber floor, marble floor, granite floor, terrazzo floor, solid wood floor, composite floor, bamboo floor, as well as other flat floor surfaces with all kinds of mirror tiles, porcelain tiles, etc. If the product is used on uneven floor surfaces, the best effect may not be achieved.
- Do not use the product near or on the surface of flammable and explosive objects, which may cause fire and explosion.
- Do not use this product near the working fireplace or heater to prevent deformation of the machine enclosure.
- Do not use this product to absorb high temperature substances (unextinguished cigarette butts, matches, hot ashes, etc.), ultra-fine substances (lime, cement, wood chips, gypsum powder, ashes, carbon powder, etc.), dangerous goods (solvents, descaling agents, etc.), chemical substances (acids, cleaners, etc.) and other substances with uncertain physical properties.
- Do not use this floor washer to absorb detergent, kerosene, gasoline, alcohol, paint, perfume, etc. These liquids may cause short circuit, fire or explosion to the machine.
- Do not use this floor washer to absorb toner used in laser printer and copier. These objects may cause fire or explosion.
- Do not touch the plug or any live part of the product with wet hands to avoid the risk of electric shock.
- Do not use the product if the plug is damaged. Please call our professional maintenance personnel for replacement to avoid danger.
- Please keep the airflow passage and moving part of this product away from long hair, loose clothing, fingers and other parts of the body. Do not point the vacuum tube, accessory suction head or tool to the eyes or ears, or put them into the mouth.
- Please use the cleaners produced by our company or our approved manufacturer.
- Do not add other solutions to avoid the generation of toxic and harmful gases. In the process of operation, if electric leakage or high temperature and abnormal sound of motor is found, such as overheating of the machine body, abnormal sound, odor, low suction, etc., please stop the machine immediately and call our professional maintenance personnel.
- After the machine is used, please clean the dirty water tank in time to prevent odor, and keep the ventilation passage clear to avoid suction drop and motor heat caused by blockage which will affect the service life of the floor washer.
- Please keep the machine in a dry place after use. Otherwise, the insulation and service life of the appliance will be affected if it is stored in a humid place.
- The machine body and the floor brush of the floor washer are equipped with power-up unit and cannot be soaked or rinsed with water.
- Please check the suction nozzle regularly to make sure it is clear. If any blockage

RECAUTIONS

- is found, please remove it in time to avoid suction drop caused by the blockage which will affect the performance of the machine.
- When replacing the roller brush, please make sure that the machine has been turned off.
 - In case of failure of the machine, do not repair it by yourself. Please our after-sales department for help.
 - In the case of below situations do not use the appliance and send it immediately to the nearest approved maintenance facility :
 - (1) The appliance fell and consequently damaged.
 - (2) The power cord is damaged.
 - Do not dismantale the closed machine by yourself. Customers cannot repair any parts of the machine by themselves. And do not try to change the performance of the machine, otherwise it will cause danger.
 - The use of voltage that does not conform to the specifications of this product will damage the product and even cause injury to the user. The correct rated voltage is indicated on the nameplate.
 - When cleaning stairs with this product, extreme caution should be exercised to prevent falling.
 - Do not shake the machine up and down, or do not make the machine suffer violent collision, so as to prevent dirty water from flowing into the motor.
 - When the motor is working, do not lift or carry the machine, or do not put the machine to one side or lay the machine flat , so as to prevent dirty water from flowing into the motor.
 - The machine should be placed against the wall after use to prevent tripping accident.
 - The machine can only be used when the clean and dirty water tanks are properly installed.
 - Do not place any small objects in the air outlet of the machine, and do not block the air outlet. Take away all small objects that may affect the smooth air flow of the air outlet to prevent the machine from overheating.
 - Do not wet the machine body, otherwise the machine may be damaged by short circuit and cause fire.
 - All the technical and other data reflected in this product manual are obtained by our company or the designated third party testing company, and our company reserves all the right for final interpretation.

ABOUT THE SCOPE OF USE OF THE PRODUCT

- Do not use this floor washer to absorb sharp or large objects, such as glass fragments, small toys, pins, paper clips, little stones, gypsum, large pieces of paper, etc. These objects may cause blockage and damage to the machine.
- Do not use this floor washer to absorb burning or smoking objects, such as ashes from unextinguished heat sources, burning cigarette butts or matches.
- This product is not suitable for cleaning stains with strong grease, strong stickiness or strong dyeing, such as shoe polish, paint and pigment.

PRODUCT INTRODUCTION

PRODUCT OVERVIEW

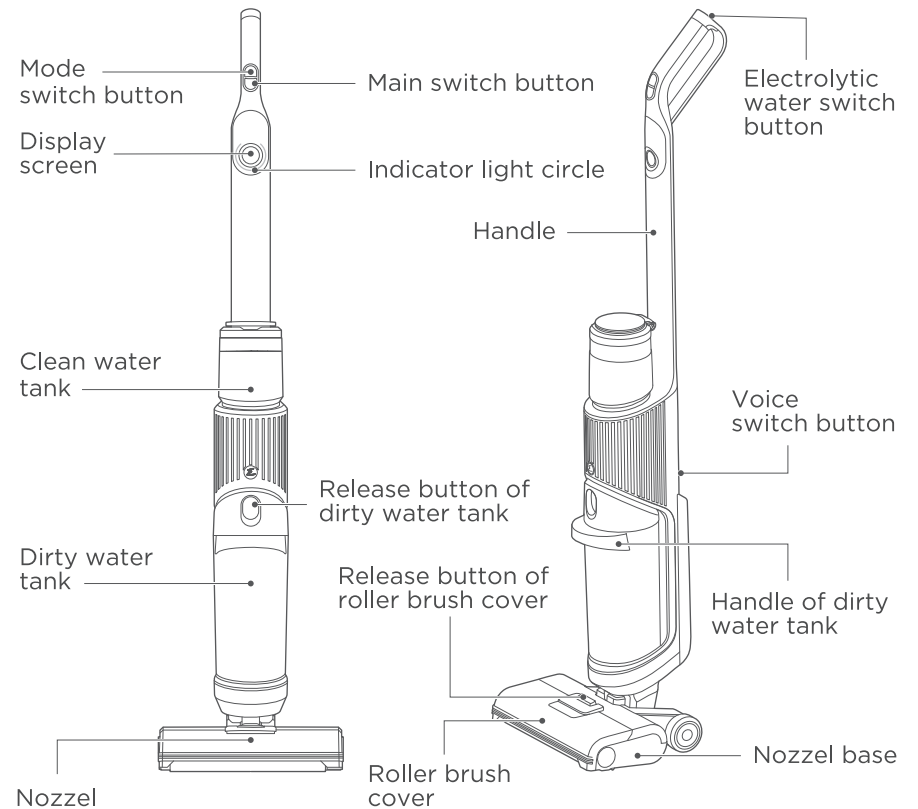

FUNCTIONS

INSTRUCTIONS FOR ASSEMBLY OF HANDLE

Insert the end of handle into the port of main body in vertical direction until it reaches the final position, and then use the souvenir coin to tighten the bolt. Make sure that the handle is tight without loosening, that is, the assembly is successful.

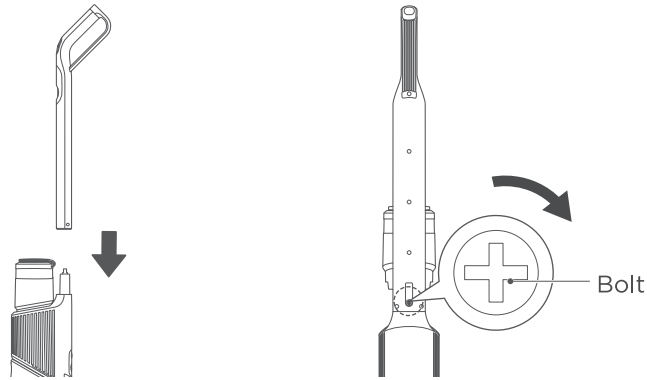

INSTRUCTIONS FOR ASSEMBLY AND DISASSEMBLY OF CLEAN WATER TANK

1. To disassemble the clean water tank, hold the machine body with one hand, and grab the clean water tank with the other hand and pull it up and out vertically.
2. To assemble the clean water tank, adjust the direction of clean water tank first, and then press it down vertically. After hearing a click, the assembly is successful.

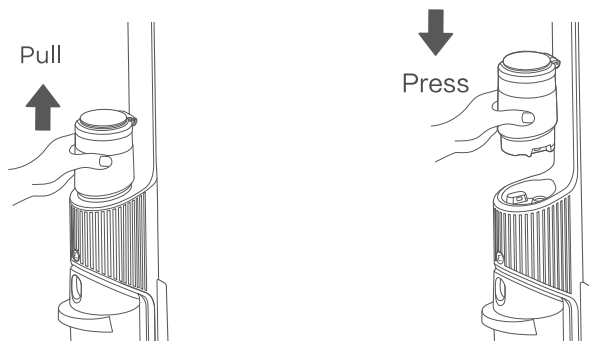

FUNCTIONS

INSTRUCTIONS FOR ASSEMBLY AND DISASSEMBLY OF DIRTY WATER TANK

1. To disassemble the dirty water tank, hold the machine body with one hand, and push the button of dirty water tank with the other hand and pull it out at the same time.
2. To assemble the dirty water tank, put the bottom of dirty water tank into the support position of machine body's opening, then gently push the tank. After hearing a click, the assembly is successful.

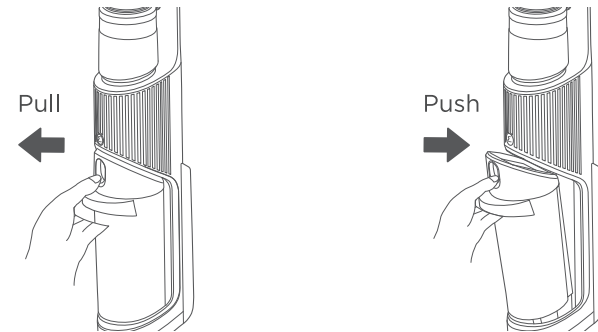

INSTRUCTIONS FOR ASSEMBLY AND DISASSEMBLY OF ROLLER BRUSH COVER

1. To disassemble the roller brush cover, apply your fingers to the position as shown in the figure, while pressing the front end of the release button with your thumb, and pull the cover out and up with your middle finger and index finger.
2. To assemble the roller brush cover, align the clasps on both ends of it with the slots on both ends of nozzle, flip it forward and press, and then press the handle of surface. After hearing a click, the assembly is successful.

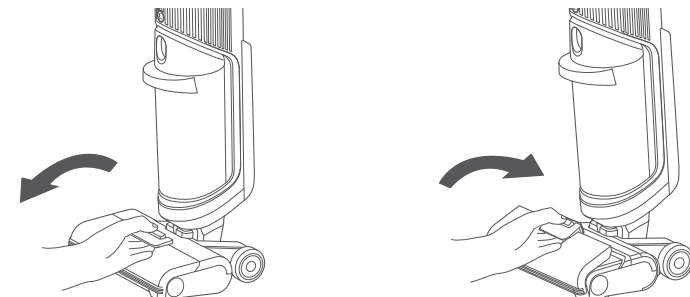

FUNCTIONS

INSTRUCTIONS FOR ASSEMBLY AND DISASSEMBLY OF ROLLER BRUSH

1. To disassemble the roller brush, just pull the roller brush handle at the left end up with your finger.
2. To assemble the roller brush, hold the roller brush handle by hand, align the right side of roller brush with the right end of cover first, then put the handle on left side of roller brush into the slot, and the assembly is successful.



PREPARATION/START OF WORK

1. Power on: After the product is fully charged, press the main switch button, and the machine will start. Press this button again, and the machine will stop.
2. Switching between automatic mode and quick suction mode: After the machine starts, it will enter automatic mode by default. Touch the automatic/quick suction mode button, and the machine will switch to quick suction mode. Press this button again, and the machine will switch to automatic mode.
3. Automatic mode: The water pump of the machine works to wet the roller brush and clean the floor.
4. Quick suction mode: The pump of machine does not work, in the mode of which the residual water on the floor can be absorbed by dry or quick suction way.
5. Electrolytic water mode: Press this button, and the real-time electrolytic water mode will be turned on, in which the germicidal ions in the water will be decomposed to disinfect the floor. Press this button again, and the electrolytic water mode will be turned off.

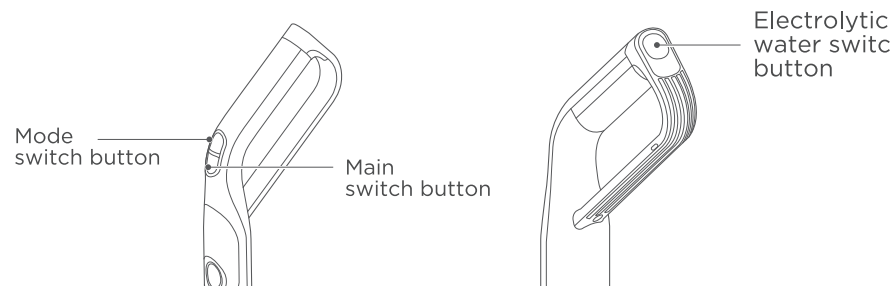

FUNCTIONS

VOICE SWITCH

When the machine is powered on for the first time, the voice function is turned on by default, which can be turned off by pressing this button, and be turned on by pressing this button again.

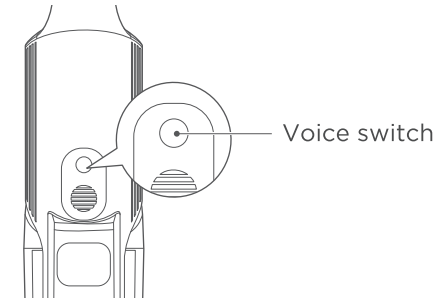

UPRIGHT SWITCH

This machine is equipped with upright switch, when the machine is placed upright, it will stop running and enter into standby mode. If there is no operation within one minute, the machine will be shut down.

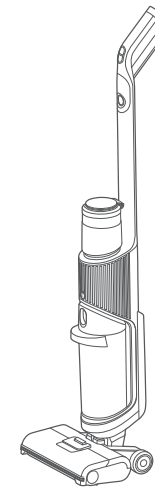

TIPS

After the machine is used, it is recommended to place it vertically on the dedicated recharge base.

FUNCTIONS

INDICATOR LIGHT CIRCLE

There is a half circle gradual changing indicator light on the machine display screen, which can indicate the floor dirt level. Red represents the floor is dirty, and blue represents the floor is clean. When the machine is used to clean heavily dirty floor, the initial color is red, and it will turn blue after cleaning.

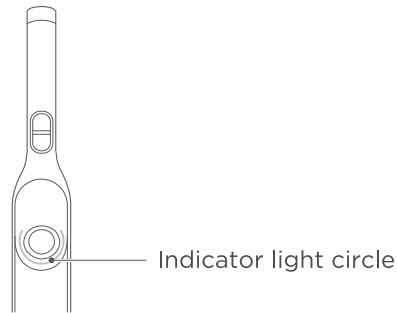

SELF-CLEANING FUNCTION

After the machine is placed on the recharge base, step on the self-cleaning pedal with your foot to start the self-cleaning operation. After completion, please clean the dirty water tank in time to avoid odor.

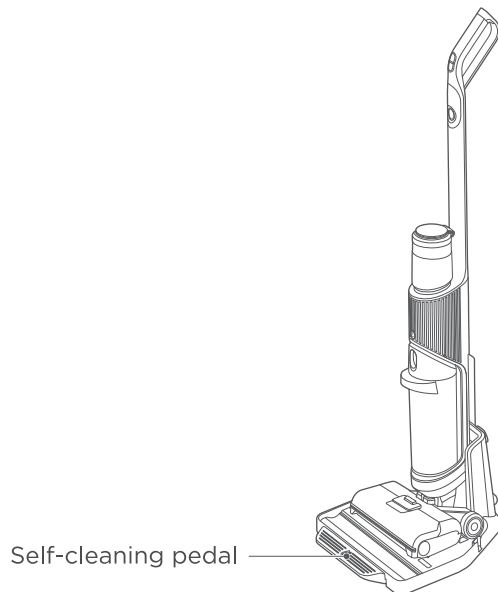

FUNCTIONS

REFILL OF CLEAN WATER TANK

1. Pull the clean water tank up vertically to remove it.
2. Open the lid of clean water tank and fill it with tap water. If deep cleaning is required, just pour the cleaning solution into the water tank again according to the specified proportion.
3. Close the lid of clean water tank, and make sure it is tight without loosening.
4. Reinstall the clean water tank to the machine body. After hearing a click, the installation is successful.
5. When the clean water tank is short of water, a voice message will be issued.

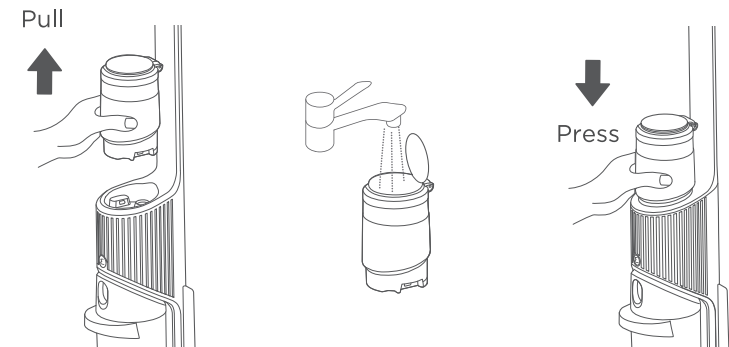

CLEANING OF DIRTY WATER TANK

1. Gently press the release button of dirty water tank to remove it.
2. Hold the tank body with one hand, and pull the lid up and out with the other hand.
3. Dispose the dirty water, and then reinstall the tank to the machine body. After hearing a click, the installation is successful.
4. When the dirty water tank is full, a voice message will be issued.

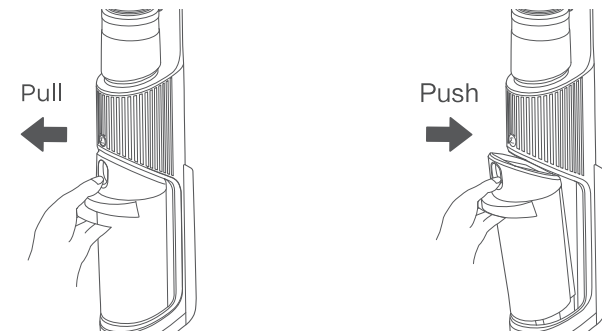

■ CLEANING AND MAINTENANCE

CLEANING OF MAIN BODY (MACHINE BODY)

⚠ CAUTION

1. After cleaning, it is recommended to place the machine upright in the tray, and be careful not to place it in direct sunlight or wet places.
2. In order to ensure the performance of the machine, it is recommended that maintenance work should be done on its parts regularly.

1. Before cleaning, please turn off the power and stop the machine.
2. Wipe it with water or neutral detergent. Be sure to wring the cleaning cloth dry before wiping to avoid water seep into the electrical components of the machine.

CLEANING OF DIRTY WATER TANK

1. When the dirty water tank is full, the float will block the air inlet of fan, and a voice message will be issued.
2. If stubborn dirt is found on the inner wall of dirty water tank, please remove it directly with the little cleaning tool.
3. After cleaning, close the lid, and reinstall the tank to the machine body. After hearing a click, the installation is successful.

CLEANING OF DIRTY WATER TANK

1. If the float is blocked in the dirty water tank, please clean it in time.
2. Remove the lid from dirty water tank and wash it with clean water.
3. After cleaning, reinstall the lid to the tank.

CLEANING OF DIRTY WATER TANK

1. First, remove the filter from the top of dirty water tank.
2. Then wash the filter with clean water. After it is completely dried, reinstall it to the tank.

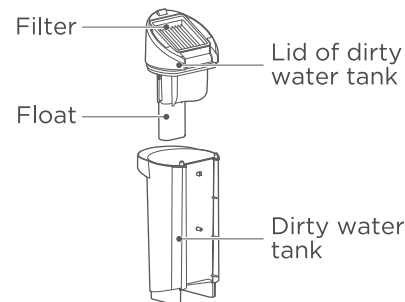

■ CLEANING AND MAINTENANCE

SELF-CLEANING

1. Before and after using the self-cleaning function, please clean the dirty water tank; if there are residual stains on the base, please clean it in time.
2. After use, please put the machine back to the base in time and step on the self-cleaning pedal to start the self-cleaning operation.

CLEANING OF ROLLER BRUSH COVER

It is recommended that after the machine is used, the roller brush cover should be washed regularly to keep it clean.

1. To disassemble the roller brush cover, apply your fingers to the position as shown in the figure, while pressing the front end of the release button with your thumb, and pull the cover out and up with your middle finger and index finger.
2. After removal, rinse the cover with clean water thoroughly until it is clean.
3. When the cleaning is completed, reinstall the roller brush cover to the nozzle base.

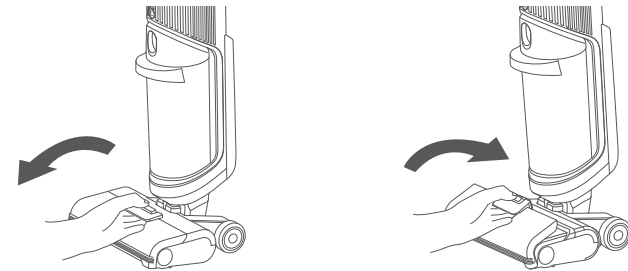

CLEANING OF ROLLER BRUSH

⚠ CAUTION

If residual stains are found at the suction nozzle, please wipe it with a wet cloth instead of rinsing it with water.

It is recommended that after each use of the machine, the roller brush should be washed and dried to keep it clean.

1. Pull the handle up on the left end of roller brush to remove the brush.
2. Disassemble the roller brush handle and use the small cleaning tool to remove the entangled hair or debris on the brush head.
3. Then rinse the roller brush with clean water.
4. After cleaning, reinstall the roller brush handle first, and then reinstall the roller brush into the floor brush. To assemble the roller brush, align its right side (without protruding structure) into the right slot first, and then push the left side (with handle) in along the left and right slots.

ANALYSIS AND SOLUTION OF COMMON PROBLEMS

If the product still can't work normally after performing the steps listed in the table below, please contact our after-sales department for help.

Common Problem	Possible Cause	Solution
The floor washer does not work	The roller brush is entangled by hair or other objects	Clean the roller brush
	Dirty water tank is full	Clean the dirty water tank
	The clean water tank is short of water Low power	Refill the clean water tank
	Low power	Recharge
Lower suction	The roller brush, roller brush cover and dirty water tank are not installed in place	Reinstall
	The roller brush is entangled by hair or other objects	Clean the roller brush
	The suction nozzle or pipe is blocked	Clean up the blockage in the suction nozzle or pipe
	The filter screen above the float is dirty	Clean the filter screen before use
	The filter for dirty water tank is dirty or missing	Clean or install the filter before use
There is abnormal sound when the fan is running	The suction nozzle is blocked	Clean up the blockage in the suction nozzle
	The dirty water in dirty water tank has reached the specified level	Remove the dirty water tank, dispose the dirty water before use
No water comes out of the floor brush	There is no water in the clean water tank	Refill the clean water tank
	The clean water tank is not installed properly	Reinstall the clean water tank
Water leaks from air outlet	No float is installed	Install the float
	The filter for dirty water tank is not dried after cleaning or using	After cleaning or using, the filter should be dried before use again
Water leaks from the bottom	The dirty water tank or its filter is not installed	Install the dirty water tank and its filter
Roller brush alert when in use	Roller brush not installed	Inatall roller brush
	Long time use of roller brush	Inatall roller brush
	Larg particles or towels Involved in the roller brush	Clean blockage
	Roller brush not installed	Inatall roller brush
Roller brush alert During self-cleaning	Roller brush not installed	Inatall roller brush
	Long time use of roller brush	Replace new roller brush

TECHNICAL PARAMETER

Model	FC9 Limited
Adapter Rated Input	100V-240V ~ 50/60HZ
Adapter Rated Output	25V-29V = 0.8A
Working Voltage	21.6V =
Rated Power	220W
Charging Time	4-6 hours
Running Time	35 min (automatic mode) 23 min (quick suction mode)



CHINA ROHS

Part Name	Substance Regulated by China RoHS					
	Pb	Hg	Cd	Cr(VI)	PBBs	PBDEs
Main body	○	○	○	○	○	○
Handle	○	○	○	○	○	○
Clean water tank	○	○	○	○	○	○
Dirty water tank	○	○	○	○	○	○
Floor brush	○	○	○	○	○	○
Battery	x	○	○	○	○	○
Accessories	○	○	○	○	○	○
Power Adapter	x	○	○	○	○	○
Motor	○	○	○	○	○	○
Electronic Circuit	x	○	○	○	○	○

Remarks:

1. This form is prepared in accordance with SJ/T 11364.
2. ○ : Indicates that the content of the hazardous substance in all homogeneous materials of corresponding part is below the limit specified in GB/T 26572.
3. X: Indicates that the content of the hazardous substance in one or more homogeneous materials of corresponding part exceeds the limit specified in GB/T 26572.
4. All components marked with X in table above comply with the EU RoHS directive, namely Directive 2011/65/EU of the European Parliament and of the Council on the Restriction of the Use of Certain Hazardous substances in Electrical and Electronic Equipment and its amendments.

WARRANTY INFORMATION

⚠ CAUTION

- 1.This product is limited for home usage and the company is not responsible for any problems caused by other usage;
- 2.For service, please directly pay attention to our WeChat official account: eureka优瑞家

eureka appliance strictly comply with government policies .
Our company provide free maintenance service for the products operated under normal usage.

- The warranty period is two years for residential or home usage, half a year for battery, three years for the motor.
- The warranty period (including main components) is six months for non residential or non home usage.
It applies to , but not limited , business offices , commercial entities , cleaning companies fleet of appliance
- During the warranty period, you will benefit from no cost home maintenance services (except for some special areas).
the no cost maintenance is only applicable to the barrel products.
- Definition of the warranty period:
 - (1) The date for issuing the valid warranty certificate should be taken as the starting date of the warranty period.
 - (2) Without a valid warranty certificate, the first day after 6 months from the delivery date should be taken as the starting date of the warranty period.
 - (3) If there is no valid warranty certificate, no packaging date, the first day after six months from market release should be taken as the starting date of the warranty period
 - (4) Date is defined as being 15 days after receiving the products; the warranty period will start from that date.
- The manufacturer is responsible for replacing the components during the warranty period; Components replacement is the responsibility of the user beyond the warranty period.
- Other matters follow the government policies.
- The warranty does not apply to the following situations:
 - (1) Appliance accessories (metal extension tube/plastic tube, hose, floor brush, small accessories, etc.), some parts (filter, dust bag, etc.) and gifts.
 - (2) The appliance is damaged due to improper usage (including storage) and operation by the user.
 - (3) The appliance is damaged due to incorrect charge voltage utilization (below 100 V or above 240 V).
 - (4) The appliance is damaged due to failure of following procedures as described in this manual for maintenance, cleaning and usage.
 - (5) Disassembly, repair by people other than the company's specialized service personnel.
 - (6) Damages due to natural causes (such as lightning, fire, earthquake, floods and other natural disasters).
 - (7) The warranty period has expired.
 - (8) The product type or serial number noted on the invoice or warranty card is not in conformity with the actual product.
- If any of the above written situations arise, the user will solely bear all the charges related to the maintenance including the cost of spare parts. The cost is defined according to standard charges.
- Any commitment for extra services, additional gifts made by original agents, distributors or retailers are their sole responsibility and the manufacturer cannot be held responsible or liable.

WARRANTY CARD

⚠ CAUTION

- 1.This warranty card should be immediately filled after purchase.
- 2.Keep this warranty card for your records; it does not need to be returned to eureka.
- 3.Bring / provide the warranty card and original invoice for service requests.

Warranty card

User name _____

Tel _____

Contact address (Post code) _____

Purchase location name and address _____

Service/maintenance supplier _____

Serial No. _____

Invoice No. _____

Purchase date _____

Record of Maintenance

Date _____

Problem description _____

Product model _____

Detailed information _____

Service technician name _____

Tel _____

Service technician signature _____

Tip: original proof of purchase (store invoice) is required for any service request.S

Jiangsu Midea Cleaning Appliance Co.,Ltd

Address: No.39 Caohu Avenue, Xiangcheng Economic Development Zone, Suzhou

Post: 215000

Version No. :FC9 Limited10-06-R1.0

Executive standard: GB4706.7-2014/GB4706.1-2005/GB4343.1-2018/GB17625.1-2012



scan WeChat for service

eureka

用户指南

感谢您采购eureka产品！
使用产品前请仔细阅读本说明书
并请妥善保存。



智能洗地机

FC9 Limited



目录

安全说明	3
关于清洁溶液	4
产品介绍	5
功能操作	6
清洁保养	12
常见问题分析及处理	14
产品技术参数	15
中国RoHS	15
保修须知	16
保修卡	17

安全说明

在使用本产品之前，请仔细阅读本说明书的所有内容，按照本说明书的步骤安装机器。妥善保管本说明书。如果您将产品传给第三方使用，请将本说明书连同机器一起随附。任何同说明书指引内容不符的操作，都有可能对产品损坏或严重的人身伤害。本产品仅适合在常规家庭环境中操作使用，不适合在工业或者在室外使用。产品不适用于身体、感官或智力上有缺陷的人士或缺乏经验和常识的人士(包括儿童)，除非有他人看管或指导，以确保其能够安全使用。

- 本产品适用于家庭室内环境中的硬性地面,包括已上蜡地板、石磨地板、橡胶地板、大理石面、花岗岩地面、水磨石地面、实木地板、复合地板、竹地板及各种镜面砖、瓷面砖等平整地表面。若在凹凸不平的地表面使用本产品时可能会达不到最佳使用效果。
- 不要在易燃、易爆的物体附近或表面使用本产品，有导致火灾和爆炸的风险。
- 不要在工作着的壁炉、加热器附近使用本产品，防止机器外壳变形。
- 请勿抽吸高温物质(未熄灭的烟头、火柴或热灰等)、超细物质(如石灰、水泥、木屑、石膏粉、灰烬、炭粉等)、危险物品(如溶剂、除垢剂等)、化学物质(如酸性物质、清洁剂等)以及其他物理特性不确定的物质。
- 请勿利用本洗地机吸取洗涤剂、煤油、汽油、酒精、油漆、香水等，这些液体可能导致机器短路、火灾或爆炸。
- 请勿利用本洗地机吸取激光打印机、复印机内部使用的调色剂、色粉，这些物体可能导致火灾或者爆炸。
- 请勿利用本洗地机吸取尖锐或大块的物体，比如玻璃碎片、小玩具、别针、回形针、石子、石膏、大的纸片等，这些物体可能造成堵塞，损伤机器。
- 请勿利用本洗地机吸取任何燃烧或冒烟的物体,例如未熄灭热源的烟灰、燃烧的烟头或火柴等。
- 类似鞋油、油漆、颜料等具有强油脂、强粘性或强染色性的污渍，不在本产品使用范围内。
- 请勿以湿手触碰插头或产品的任何带电部分，以免发生触电危险。
- 如果插头损坏，请停止使用。请致电本公司专业的维修人员进行更换，以避免发生危害。请将本产品气流通道和活动部分远离长毛发、宽松服装、手指及身体其他部分。请勿将吸尘管、附件吸头或工具对着眼睛、耳朵，或将其放入口中。
- 请使用本公司及本公司核准的制造商生产的清洁剂，不要加入其它溶液，避免产生有毒有害气体。
- 使用时，若发现漏电或电动机温度过高和异常声响，如机身过热、异声、异味、吸力弱等，应立即停止使用并致电本公司专业的维修人员。
- 使用完机器后，请及时清理污水桶避免异味，并保持通风路径畅通，避免阻塞造成吸力下降、电机发热，从而影响洗地机的使用寿命。
- 使用完机器后，请放在干燥的地方保存，潮湿的地方会影响电器的绝缘性和使用寿命。洗地机机身、地刷有通电设置，不能泡水或冲洗。
- 请定期检查吸嘴口的畅通情况，若有堵塞，请及时清除，避免阻塞造成吸力下降，影响到机器的使用性能。
- 请确保关机后再更换滚刷。
- 下列情形时，请不要使用机器，并及时送至本公司指定的维修部检修：
 1. 发生跌落并出现明显损坏或运转不正常；
 2. 电源线破损。
- 不要自行拆装封闭的机器，本机器内没有顾客可自行维修的部件，也不要试图改变机器的性能，否则将导致危险。
- 使用与本产品规格不对应的电压将对产品有损害，更有可能对使用者造成伤害，正确的额定电压标示于铭牌上。

安全说明

- 清扫楼梯时，应格外谨慎小心，防止跌落。
- 不要将机器上下晃动或剧烈碰撞，防止污水流入电机。
- 当电机正在工作时，请不要上下提起或搬运本电器，也不要将本机器至向一边或平放，防止回污水进入电机。
- 为了防止绊跌，机器使用后，应靠墙放置。
- 若清水箱和污水箱没有正确安装好，请勿使用。
- 不要在出风口放置任何小物件，也不要将出风口堵塞，取走一切有可能妨碍出风口气流顺畅的小物件，防止机器过热。
- 不要弄湿机身，否则有可能因机器短路损坏而发生火灾。
- 本产品说明书内所有体现出来的技术及其他数据由我公司或指定第三方测试公司获得，最终解释权归我公司所有。

关于清洁溶液

- 按照使用说明配比清洁。建议使用本公司及本公司核准的制造商生产的清洁剂，不得含有酸、碱溶液或对环境有害的物质。
- 如果加入大量的清洁溶液，使用时会产生较多的泡沫，可能会渗透到电机导致危险。
- 清洁剂应保管在儿童触及不到的地方，如果清洁溶液不慎入眼，应用清水彻底冲洗干净；万一不小心误食，应立即就医。在处理污水和清洁溶液时，应遵循当地的环保规定。

产品介绍

产品概述

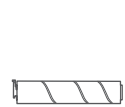
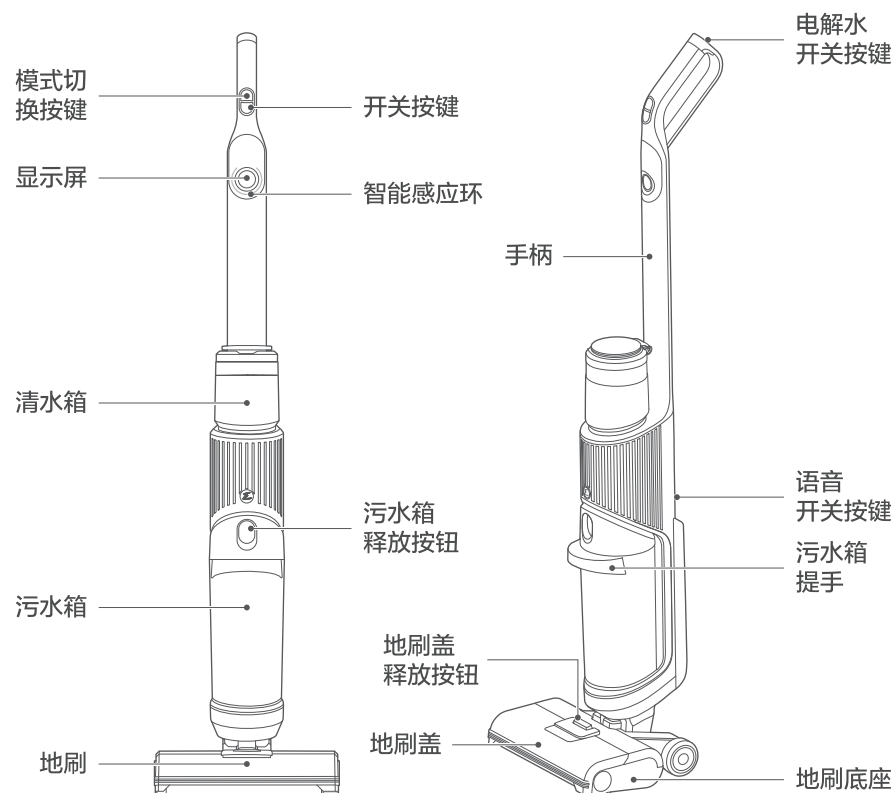

滚刷



清洁刷

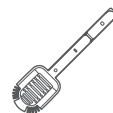

清理勺

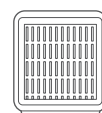

海帕



附件架



螺栓与纪念币



清洁液

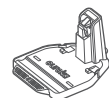

充电座

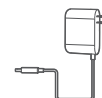

适配器

功能操作

手柄安装说明

将手柄末端沿垂直方向插入主机的端口内，插到底部位置后使用纪念币将螺栓拧紧，确保手柄紧实无松动，即安装成功。

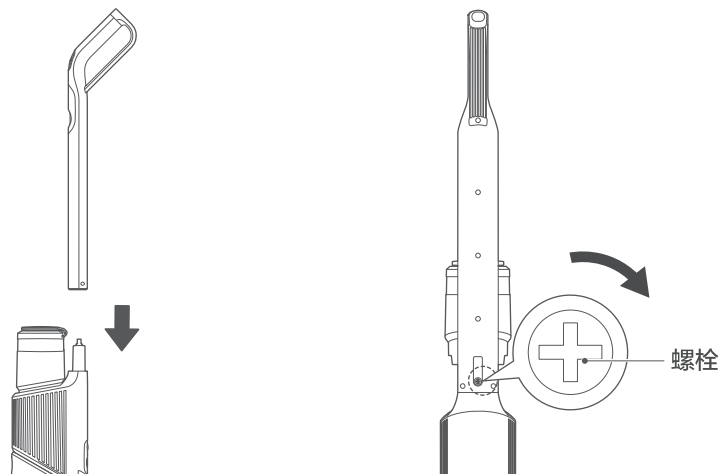

清水箱拆装说明

1. 若要取下清水箱，一只手扶住机身，另一只手握住清水箱垂直向上拉，便可将箱体取出。
2. 若要安装清水箱，先将清水箱调整好方向，然后垂直向下按压，听到咔声后即安装成功。

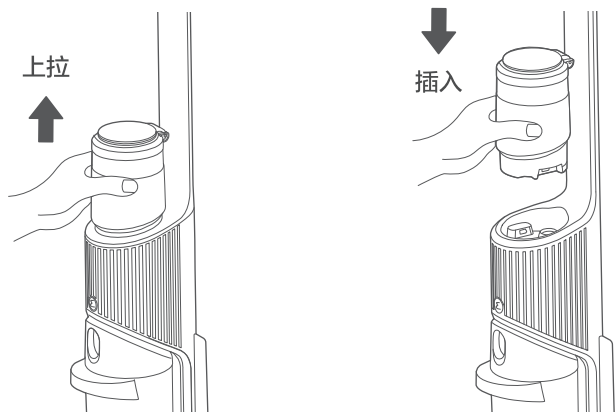

功能操作

污水箱拆装说明

1. 若要取下污水箱，一只手扶住机身，另一只手扣动污水箱按钮，同时往外拉，即可将箱体取出。
2. 若要安装污水箱，先将污水箱的底部放进机身的开口支撑位置，然后轻推污水箱，听到咔声后，即安装成功。

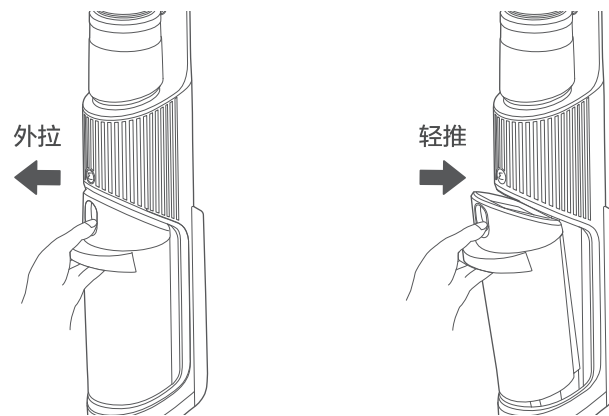

地刷盖拆装说明

1. 若要取下地刷盖，如图所示位置按压释放按钮前端，中指和食指同时向外拉起，取出地刷盖。
2. 安装时，将地刷盖两端的卡扣对准地刷两端卡槽，按压面盖提手，听到咔声后，即安装成功。

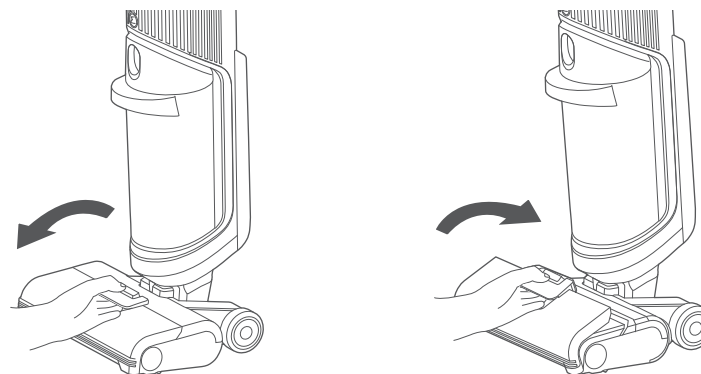

功能操作

滚刷组件拆装说明

1. 若要取下滚刷，如图所示拉起左端滚刷提手，即可取下。
2. 安装时，用手捏住滚刷提手，将滚刷的右边先对准右端盖，再将滚刷左端提手放入槽中，滚刷即可安装成功。

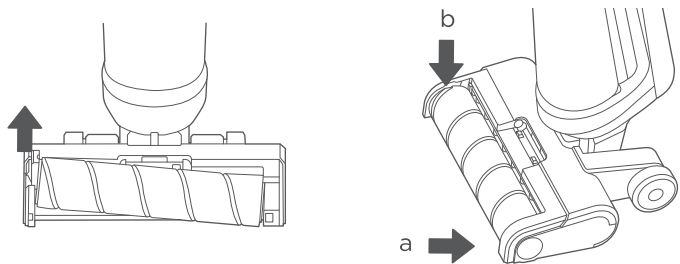

准备工作/开始工作

1. 开机：产品充满电后按下开关按钮，即可开机，再次按下此按钮，机器停止工作。
2. 自动/速吸模式切换：整机启动默认进入自动模式，触动自动/速吸模式按键，机器切换至速吸模式，再次按下此按钮，机器切换至自动模式。
3. 自动模式：整机水泵工作，湿润滚刷绒毛，进行地板清洗。
4. 速吸模式：整机水泵不工作，可干吸或速吸地面残水。
5. 电解水模式：按下此按钮，将开启实时电解水模式，在水中分解出杀菌离子，从而对地面进行杀菌，再次按下此按钮，自动模式状态下电解水模式关闭。

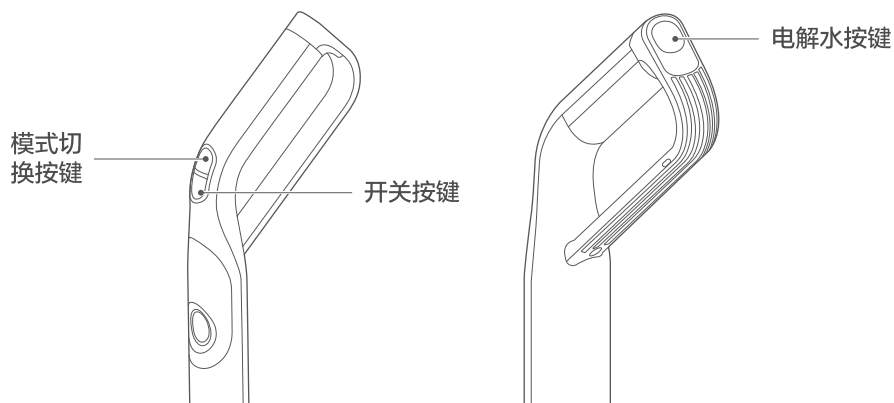

功能操作

语音开关

整机第一次开启时默认语音开启，可按下此按钮关闭语音，再按此按钮开启语音。

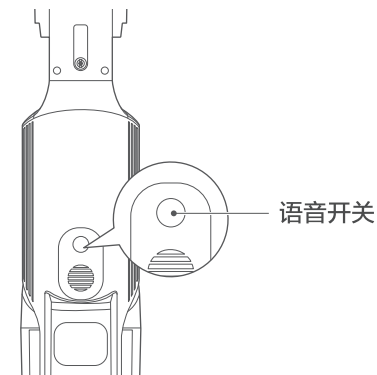

直立开关

本机自带直立开关，整机直立放置时，整机停止运转并处于待机模式；待机一分钟内若无操作，机器进入关机状态。

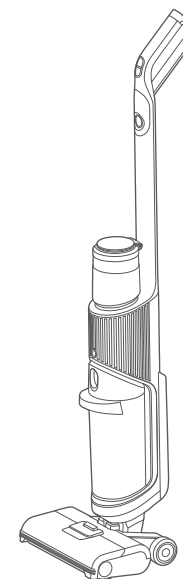

提示

使用完机器之后，建议将其垂直放置于为您专配的充电座上。

功能操作

智能感应环

整机显示屏有半周圈渐变指示灯，用来指示脏污程度，红色代表脏污，蓝色代表洁净，当在脏污较重的地面清洁时，蓝色占比越大，表示地面越干净；初始为红色，清洁干净后将显示为蓝色。



自清洁功能

将整机放入充电座后，确保充电指示电量处于绿色状态下，用脚踩自清洁踏板，开始自清洁功能，完成后请及时清理污水箱，避免异味。

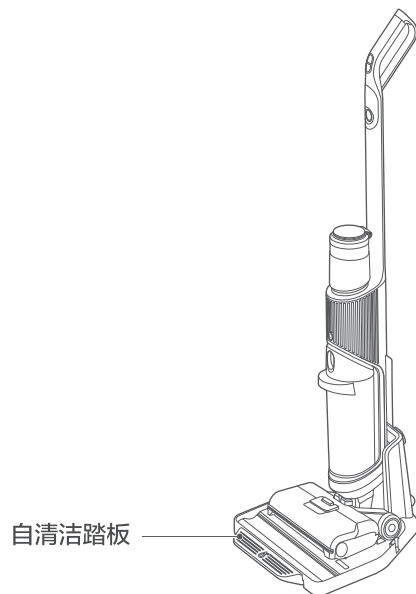

功能操作

清水箱注水

1. 垂直向上拔出清水箱，取下清水箱；
2. 打开清水箱上盖，将自来水注入至水箱。若需进行深度清洁，可按规定比例再将清洁液倒入水箱即可；
3. 将清水箱的上盖盖紧，确保紧实无松动；
4. 将清水箱安装回机身，听到咔声后即安装成功；
5. 清水箱缺水时，会有语音播报提示。

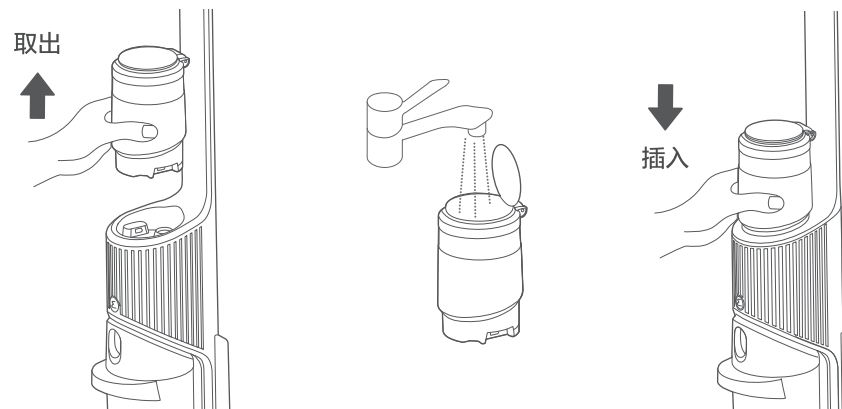

污水箱清理

1. 轻按污水箱释放按钮，将污水箱取下；
2. 一手握住箱体，一手向上拔出污水箱盖；
3. 污水清理后，将污水箱安装回机身，听到咔声后即安装成功；
4. 污水箱污水满时，会有语音播报提示。

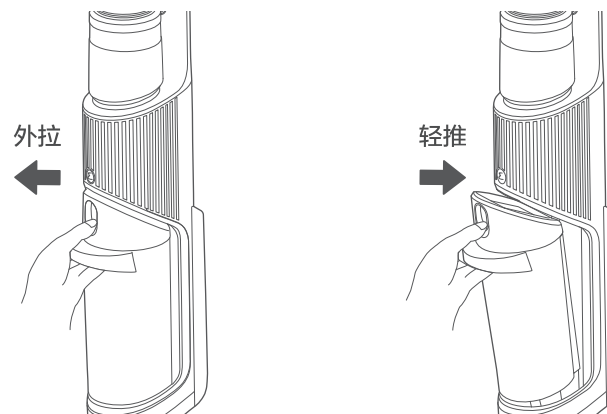

■ 清洁保养

清理主机（机身）

▲ 注意

1. 清理完之后，建议将整机直立放置在托盘中，注意不要放在阳光直射或者潮湿的地方。
2. 为了不影响机器的使用性能，建议您定期对其部件进行维护。

1. 清洁之前，请先断开电源，让机器停止工作；
2. 用水或中性的洗涤剂擦洗，擦洗前务必将清洁布拧干，切勿将水渗入机器电器元件内部。

污水箱清理

1. 当污水箱吸满污水后，浮子会堵住风机进气口，会有语音播报提示；
2. 若发现污水箱内壁有顽固污垢，请直接用清理小工具清洗即可；
3. 清理完成后，合上污水箱盖，装回至机身，听到咔声后即安装到位。

清理浮子

1. 若发现浮子在污水箱内被堵塞，请及时清理；
2. 将污水箱上盖取下，然后用清水冲洗；
3. 清理完成后，装入污水箱。

清理污水箱过滤器

1. 先将过滤器从污水箱上方取出；
2. 取出后用清水洗净，彻底晾干后，装入污水箱。

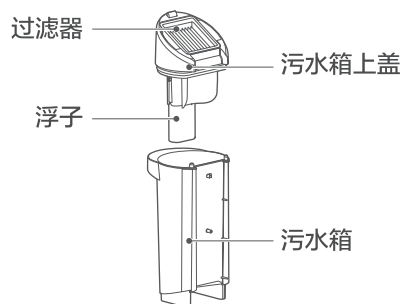

■ 清洁保养

自清洁

1. 使用自清洁功能前、自清洁结束后，请清理污水箱；若底座上有残留污渍，请及时清理；
2. 使用完毕后请及时将机器放回底座，踩下自清洁踏板，开始自清洁。

清理地刷盖

建议整机使用完后，定期对地刷盖进行清洗，以保持干净整洁。

1. 先将手指作用于如图所示位置同时拇指按压释放按钮前端，中指和食指向外拉起，取出地刷盖；
2. 取出后，用清水进行冲洗，直到干净为止；
3. 清理完成后，将地刷盖装入地刷底座中。

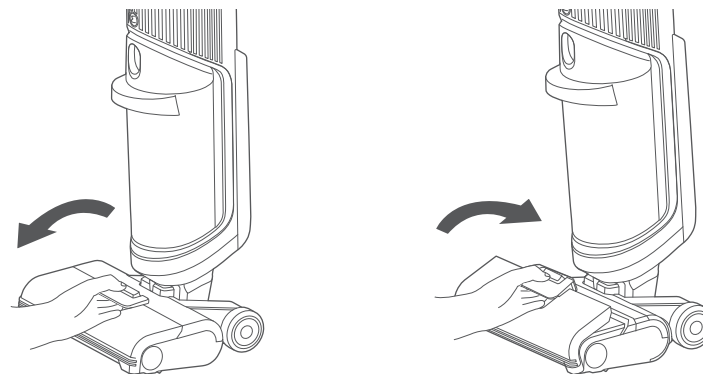

清理滚刷

▲ 注意

如发现吸嘴口有残留污渍，请用湿抹布擦拭，切勿用水冲洗。

建议每次使用完后，及时对滚刷进行清理并晾干以保持干净整洁。

1. 拉起滚刷左端提手，取下滚刷；
2. 可将滚刷提手取下，使用滚刷清理小工具将刷头上的缠绕的毛发或者碎屑等去除；
3. 然后用清水对滚刷进行冲洗；
4. 清理完成后，先将滚刷提手安装好，再将滚刷安装至地刷内。安装时，请先将滚刷右边（无突出结构）对入右边槽内，再将左边（带有提手的一端）顺沿着左槽推入。

常见问题分析及处理

如若按照下表步骤仍不能使产品正常工作，请联系我公司的售后服务部门以获取帮助。

常见问题	可能的原因	解决方法
洗地机不工作	滚刷被毛发等物体缠绕	清理滚刷
	污水箱满	清理污水箱
	清水箱缺水	清水箱加水
	电量低	充电
产品吸力减弱	滚刷、滚刷盖、污水箱安装不到位	重新安装
	滚刷被毛发等物体缠绕	清理滚刷
	吸风口或管道被堵塞	清理吸风口或管道内的障碍物
	浮子上方滤网脏污	清理滤网后再使用
	污水箱过滤器脏污或漏装	清理或安装过滤器后再使用
风机运转有异音	吸风口被堵塞	清理吸风口内的障碍物
	污水箱污水已到指定容量	取出污水箱，倒掉污水再使用
地刷不出水	清水箱无水	清水箱加水
	清水箱未安装到位	将清水箱重新安装
出风口漏水	未安装浮子	安装浮子
	污水箱过滤器清洗、使用后未晾干	清洗、使用后晾干再使用
地刷底部漏水	未安装污水箱或污水箱过滤器	安装污水箱及过滤器
使用中滚刷报警	未安装滚刷	安装滚刷
	滚刷使用时间过长	更换滚刷
	大颗粒或毛巾等卷入滚刷	清理堵塞物
自清洁滚刷报警	未安装滚刷	安装滚刷
	滚刷使用时间过长	更换滚刷

产品技术参数

型号	FC9 Limited
适配器额定输入	100V-240V ~ 50/60HZ
适配器额定输出	25V-29V = 0.8A
工作电压	21.6V =
额定功率	220W
充电时间	4-6小时
使用时间	35Min (自动模式) 23Min (速吸模式)



中国ROHS

零部件名称	中国RoHS管控物质或元素					
	铅	汞	镉	六价铬	多溴联苯	多溴二苯醚
大身组件	○	○	○	○	○	○
手柄组件	○	○	○	○	○	○
清水箱组件	○	○	○	○	○	○
污水箱组件	○	○	○	○	○	○
地刷组件	○	○	○	○	○	○
电池	×	○	○	○	○	○
附件	○	○	○	○	○	○
电源适配器	×	○	○	○	○	○
电机组件	○	○	○	○	○	○
电子电路	×	○	○	○	○	○

备注：

1. 本表格依据SJ/T 11364的规定编制。
2. ○：表示该有害物质在该部件所有均质材料中的含量均在GB/T 26572规定的限量要求以下。
3. ×：表示该有害物质至少在该部件的某一均质材料中的含量超出GB/T 26572规定的限量要求。
4. 本表中的有×的所有部件均符合欧盟的RoHS指令，即“欧洲议会和理事会关于在电子电气设备中限制使用某些有害物质的第2011/65/EU号指令”及其修正案。

■ 保修须知

▲ 注意

1. 本产品只限于家用，非家用出现任何问题本公司概不负责；
2. 如您发现产品需要服务时，请关注微信公众号：eureka优瑞家，获取相应服务信息。

eureka真空吸尘器严格遵照国家“新三包”规定进行保修服务。
用户在正常使用产品的情况下，提供相关免费维修服务。

- 家庭整机保修两年，电池保修半年，电机保修三年。
- 非家庭整机及其主要部件保修半年。
如：经营、商用、公司集体的产品。
- 保修期内用户可享受免费上门维修（特殊地区除外）服务。
“免费上门维修”限桶吸产品。
- 保修期界定：
 1. 以有效保修凭证的开具日期作为保修期的起始日期；
 2. 没有有效保修凭证的，按出厂日期后6个月作为保修期的起始日期；
 3. 若既无有效保修凭证也无出厂日期的，则按该产品的最早上市日期后6个月作为保修期的起始日期；
 4. 网购产品15天界定定期以收货日期计算，后期保修可按发票日期计算。
- 保修期内维修更换的零部件归本公司所有，保修期外维修更换的零部件归用户所有。
- 其他事项按照国家“新三包”规定执行。
- 凡属下述情况之一的，不在保修范围内：
 1. 吸尘器附件（金属伸缩管/塑料接插管、软管、地刷、小附件等），耗材（滤芯、集尘袋等）和赠品；
 2. 用户搬运、使用、维护、保管不当而损坏的；
 3. 使用充电电压低于100 V 或者高于240 V 而损坏的；
 4. 未按产品使用说明书要求使用、维护、保养而造成损坏的；
 5. 非本公司专业服务人员拆卸、维修的；
 6. 因不可抗力（如雷电、火灾、地震、水灾等自然灾害）造成损坏的；
 7. 产品超出保修期的；
 8. 发票或保修卡上记录的型号或编号与商品实物不符合的。
- 以上情况我公司将实施收费维修，费用类型包括维修费、零部件费，具体费用标准在相关部门允许范围内。
- 由代理商、经销商、零售商自行承诺的额外服务与附加的非原厂配置赠品，由原代理商、经销商、零售商负责服务。

■ 保修卡

▲ 注意

1. 此保修卡在购买公司产品时立即填写；
2. 此保修卡请妥善保存，购买者不必将卡寄回本公司；
3. 维修时请携带此证及有效发票正本。

保 修 卡

用户姓名

电 话

通讯地址(邮编)

购买商店

维 修 点

编 号

发票号码

购买时间

维修记录

日 期

故障内容

产品型号

处理内容

维修单位名称

电 话

维修员签名

提示：修理时需出具发票。

售后电话：400-001-0562

江苏美的清洁电器股份有限公司

地址：苏州市相城经济开发区漕湖大道39号

编码：215000

版本号：FC9 Limited10-06-R1.0

执行标准：GB4706.7-2014/GB4706.1-2005/

GB4343.1-2018/GB17625.1-2012

产品合格证

检查结论：合格

检查员号：检验员A1

检查日期：见生产批号

江苏美的清洁电器股份有限公司



微信扫一扫，服务立马到