

eureka®

Owner's Guide

Thank you for purchasing your new Eureka machine! Please read this Owner's Guide carefully before operating, and keep it properly.



Lightweight Corded Stick Vacuum

V19P11A510CN

PRODUCT INTRODUCTION

PRODUCT OVERVIEW

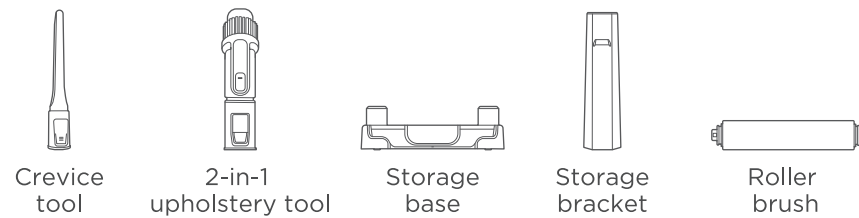
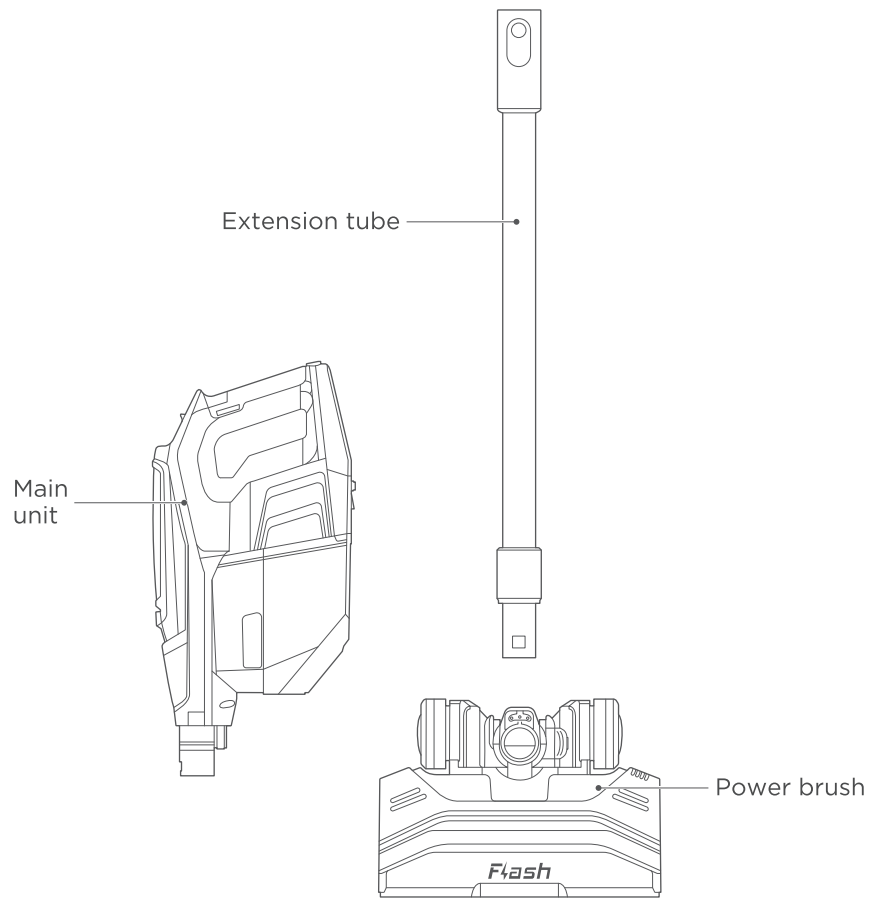

OPERATIONS

ASSEMBLY

1. Connect the main unit of the handheld vacuum cleaner to the extension tube;
2. Connect the extension tube with power brush.

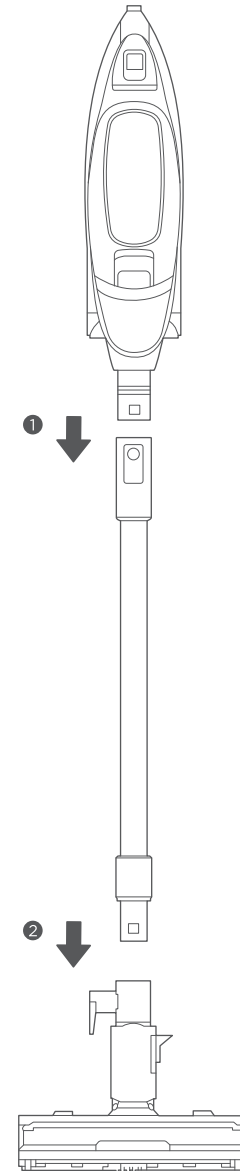

OPERATIONS

CLEANING

1. Push the power button to start cleaning. The first position is low speed for floor cleaning, and the second position is high speed for carpet cleaning;
2. Before use, it is necessary to clean up large or sharp objects (such as screws, etc.) in the area, and start cleaning by moving the power brush back and forth;
3. After use, slide the button to the off position.

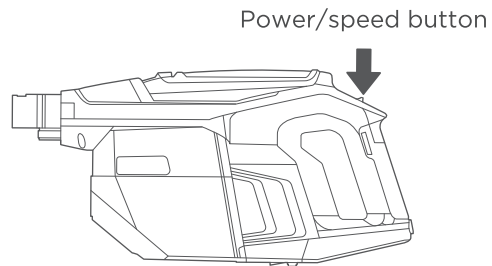

ASSEMBLY OF STORAGE BASE

Install the storage bracket and the storage base according to the position shown in the figure, and place the assembled storage base on a horizontal surface according to the right picture.

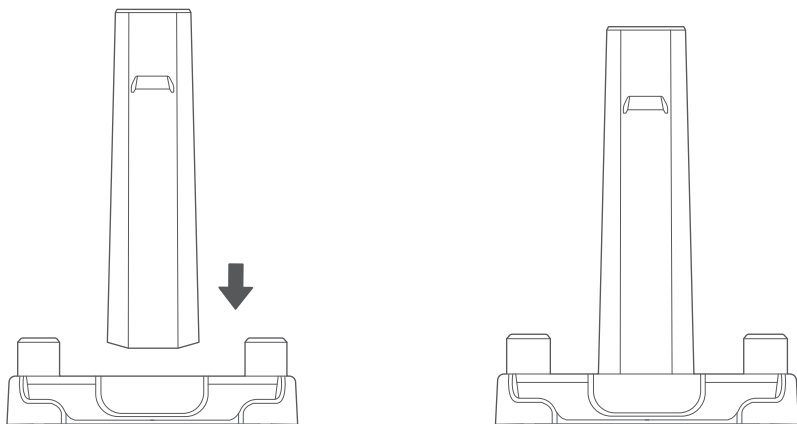

OPERATIONS

PLACEMENT OF THE MACHINE

CAUTION

1. The machine must be placed on a level surface before placing it on the storage base or when the storage base is placed separately, so as to avoid tipping and damaging the machine;
2. Regardless of whether the machine is working or placed on the storage base, always handle with care to avoid damage to the machine.

1. Press the release button on the upper end of the extension tube to separate the main unit from it;
2. Keep the extension tube connected to the it power brush, and place the brush on the corresponding position of the storage base, as shown in the right figure;
3. Align the groove at the air outlet of the main unit with the buckle of the storage bracket, and fix the main unit on the other side of the storage bracket. The power cord can be wound around the winding hooks of the extension tube.

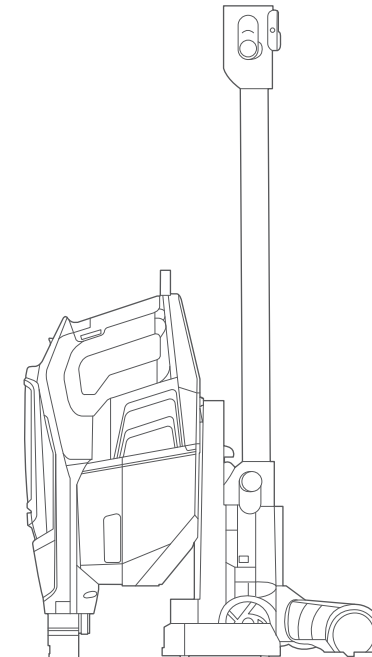

CLEANING AND MAINTENANCE

DISASSEMBLY AND CLEANING OF THE DUST CUP

CAUTION

To maintain the suction power of the vacuum cleaner, please clean the dust regularly.

Remove the dust cup assembly as shown in the figure, then remove the upper cover of the dust cup through the metal pull ring and dump the dust.

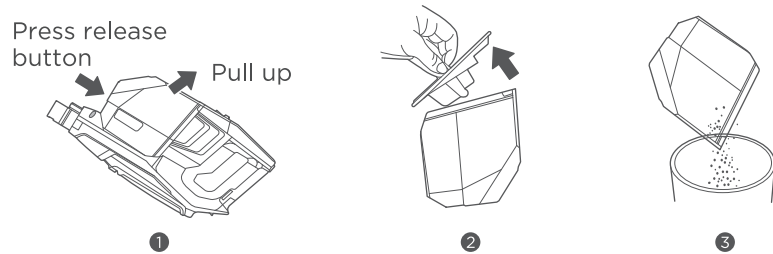

DISASSEMBLY AND CLEANING OF THE FILTER

CAUTION

1. Filter cotton is washable;
2. Please make sure that each part is fully dry before installing after cleaning.

1. Push the cover release button on the top of the main unit to open the cover;
2. Take out the two pieces of filter cotton upwards, shake off the surface dust, rinse with water and dry it in the sunlight for 24 hours;
3. After the filter cotton is dried, reinstall it in the machine and put back the upper cover.

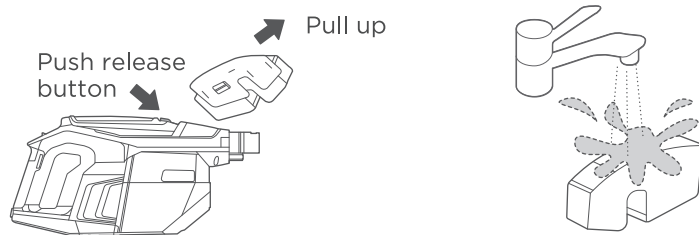

CLEANING AND MAINTENANCE

DISASSEMBLY AND CLEANING OF THE POWER BRUSH

CAUTION

1. In order to avoid affecting the operation of the power brush, perform cleaning and maintenance when the roller brush or wheels are entangled or dirty;
2. Before disassembling and maintaining, be sure to stop the operation of the power brush.

1. Entangled hair can be cleaned with scissors or blades, as shown;

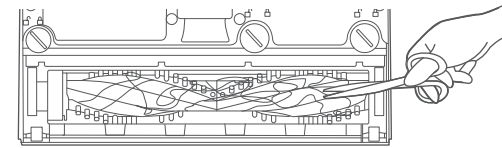

2. For debris that is not easy to clean, you can use a flat-blade screwdriver or a coin to turn the knob to the unlock position, and open the brush plate for cleaning. The details are shown;

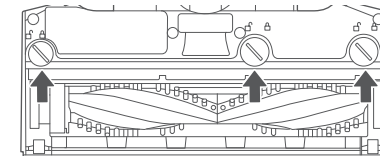

3. After cleaning, reinstall the brush plate, insert one end of the plate into the hole position of the brush, press the other end of the plate into the matching hole, and turn the button to the locked position to complete the installation; Details are shown.

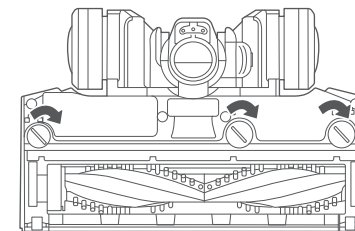

CHINA ROHS



Name of parts	Chinese RoHS controlled substances or elements					
	(Pb)	(Hg)	(Cd)	(Cr(VI))	(PBBs)	(PBDEs)
Bottom cover assembly	○	○	○	○	○	○
Top cover assembly	○	○	○	○	○	○
Handle	○	○	○	○	○	○
Motor assembly	○	○	○	○	○	○
Dust cup assembly	○	○	○	○	○	○
Extension tube	○	○	○	○	○	○
Power brush	○	○	○	○	○	○
Accessories	○	○	○	○	○	○
Electronic circuit	○	○	○	○	○	○

Remarks:

- This table is formulated according to SJ/T 11364.
- : The content of the harmful substance in all homogeneous materials of the component is below the limit prescribed in GB/T 26572.
- X: The content of the harmful substance in all homogeneous materials of the component is above the limit prescribed in GB/T 26572.
- All parts marked with X in this table comply with EU RoHS directive, i.e. "Directive 2011/65/EU Restriction of the Use of Certain Hazardous Substances in Electronic and Electrical Equipment" and the amendments.

PRODUCT PARAMETERS

Product Technical Parameters

Model	Rated Voltage	Rated Frequency	Rated Power
V19P11A510CN	220 V ~	50Hz	450 W

SAFETY INSTRUCTIONS



- Do not place the appliance close to heat sources, radiation, or burning cigarette.
Do not use the appliance to remove the following objects:
 - All liquids such as water and solvents.
 - Lime, cement, ash and other construction dust and garbage.
 - Hot objects, such as cigarette butts.
 - Sharp objects, such as glass shards, etc.
 - Inflammable and explosive articles, such as gasoline or alcohol products.
- It is forbidden to let children, mentally retarded person or person who do not have common knowledge or experience about the domestic households without surveillance.
- Your appliance is an electric appliance: It must be used appropriately. Do not leave the operating appliance unattended.
- It is not allowed to dismantle the product by non-technicians without permit.
- The product is for indoor use instead of outdoor.
- Do not touch the power cord or socket with wet hands.
- Please empty the dust cup before using the product.
- Do not pull the power plug to turn off the appliance
Hold the plastic part of the plug to remove it from the power socket.
- The power supply voltage must correspond to that of the machine using voltage.
- Keep the power cord away from sharp objects to prevent it from being damaged.
- To prevent fires, do not immerse the appliance in water, do not expose it to any heating appliances.
- Do not drag the power cord when moving the appliance.
- In the case of below situations do not use the appliance and send it immediately to the nearest approved maintenance facility :
 - The appliance fell and consequently damaged.
 - The power cord is damaged.
- Stop operating the appliance if the suction inlet is blocked to prevent damages (such as overheating) to the motor or deformations to the vacuum plastic parts occasioned by overheating motor.

WARRANTY INFORMATION

CAUTION

1. This product is limited for home usage and the company is not responsible for any problems caused by other usage;
2. For service, please directly pay attention to our WeChat official account: eureka优瑞家

Eureka appliance strictly comply with government policies .
Our company provide free maintenance service for the products operated under normal usage.

- The warranty period is two years for residential or home usage, three years for the motor.
- The warranty period (including main components) is six months for non residential or non home usage.
It applies to , but not limited , business offices , commercial entities , cleaning companies fleet of appliance
- During the warranty period, you will benefit from no cost home maintenance services (except for some special areas).
the no cost maintenance is only applicable to the barrel products.
- Definition of the warranty period:
 - (1) The date for issuing the valid warranty certificate should be taken as the starting date of the warranty period.
 - (2) Without a valid warranty certificate, the first day after 6 months from the delivery date should be taken as the starting date of the warranty period.
 - (3) If there is no valid warranty certificate, no packaging date, the first day after six months from market release should be taken as the starting date of the warranty period
 - (4) Date is defined as being 15 days after receiving the products; the warranty period will start from that date.
- The manufacturer is responsible for replacing the components during the warranty period; Components replacement is the responsibility of the user beyond the warranty period.
- Other matters follow the government policies.
- The warranty does not apply to the following situations:
 - (1) Appliance accessories (metal extension tube/plastic tube, hose, floor brush, small accessories, etc.), some parts (filter, dust bag, etc.) and gifts.
 - (2) The appliance is damaged due to improper usage (including storage) and operation by the user.
 - (3) The appliance is damaged due to incorrect voltage utilization (below 187 V or above 240 V).
 - (4) The appliance is damaged due to failure of following procedures as described in this manual for maintenance, cleaning and usage.
 - (5) Disassembly, repair by people other than the company's specialized service personnel.
 - (6) Damages due to natural causes (such as lightning, fire, earthquake, floods and other natural disasters).
 - (7) The warranty period has expired.
 - (8) The product type or serial number noted on the invoice or warranty card is not in conformity with the actual product.
- If any of the above written situations arise, the user will solely bear all the charges related to the maintenance including the cost of spare parts. The cost is defined according to standard charges.
- Any commitment for extra services, additional gifts made by original agents, distributors or retailers are their sole responsibility and the manufacturer cannot be held responsible or liable.

WARRANTY CARD

CAUTION

1. This warranty card should be immediately filled after purchase.
2. Keep this warranty card for your records; it does not need to be returned to Eureka.
3. Bring / provide the warranty card and original invoice for service requests.

Warranty card

User name _____

Tel _____

Contact address (Post code) _____

Purchase location name and address _____

Service/maintenance supplier _____

Serial No. _____

Invoice No. _____

Purchase date _____

Record of Maintenance

Date _____

Problem description _____

Product model _____

Detailed information _____

Service technician name _____

Tel _____

Service technician signature _____

Tip: original proof of purchase (store invoice) is required for any service request.S

Jiangsu Midea Cleaning Appliance Co.,Ltd

Address: No.39 Caohu Avenue, Xiangcheng Economic Development Zone, Suzhou

Post: 215000

Version No. : V19P11A510CN10-06-R1.1

PN: 16175000005942

Executive standard: GB4706.7-2014/GB4706.1-2005/GB4343.1-2018/GB17625.1-2012



scan WeChat for service

eureka®

用户指南

感谢您采购Eureka产品！
使用产品前请仔细阅读本说明书
并请妥善保存。



有线手持吸尘器

V19P11A510CN

产品介绍

产品概述

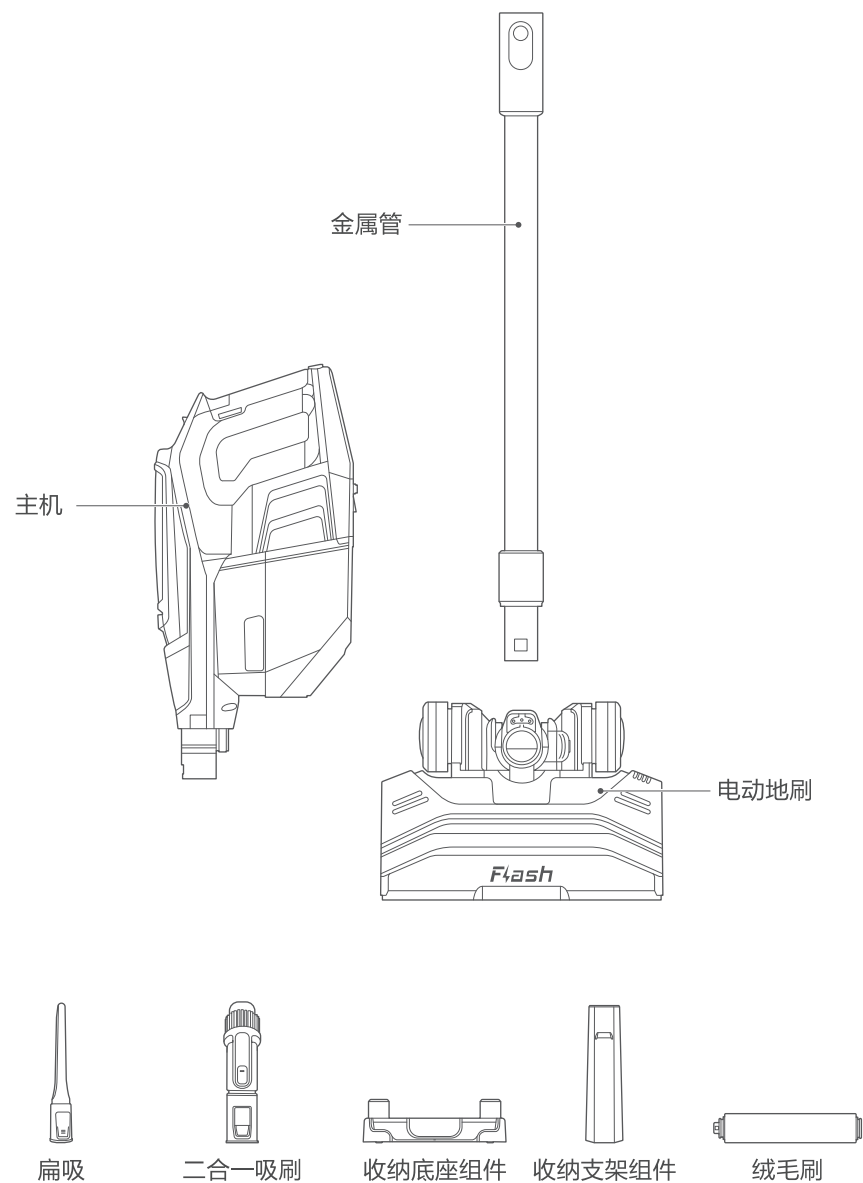

功能操作

安装

1. 将手持吸尘器主机与金属接插管相连;
2. 将金属接插管插入电动地刷接头处。

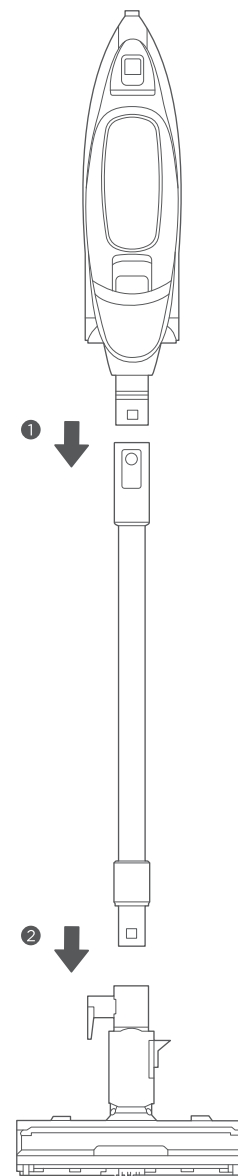

功能操作

清扫

1. 推动滑动开关开始清扫，第一个档位为低速档适用于地板清洁，第二个档位为高速档适用于地毯清洁；
2. 使用前需清理区域内大块垃圾或锋利物体（如螺丝等），通过前后移动电动地刷实现区域内清洁功能；
3. 使用完成后，将开关滑动至关闭位置。

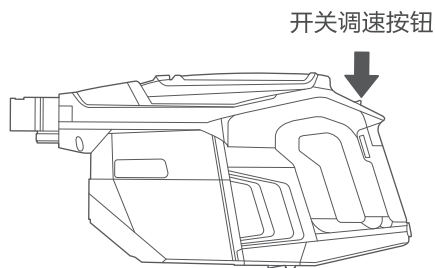

收纳架组件的安装

将收纳支架组件与收纳底座组件按图示位置安装好，并将装好的收纳架组件按右图竖直放置在水平面上。

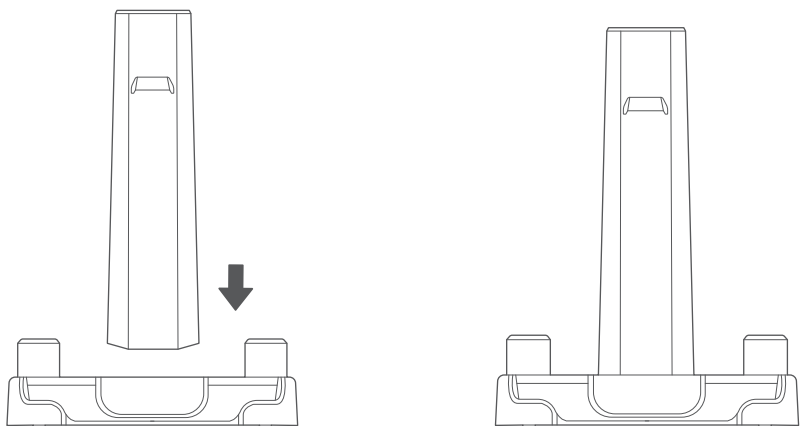

功能操作

整机的放置

⚠ 注意

1. 整机放在收纳架上之前或收纳架单独放置时都务必保证放在水平面上，以免发生倾倒，损坏机器；
2. 整机无论在工作中，或放置在收纳架上，均需轻拿轻放，以免损坏机器。

1. 按压金属管上端释放按钮，使主机与金属管分离；
2. 保持金属管与电动地刷相连，将电动地刷放置在收纳底座对应位置，如图所示；
3. 将主机出风口处凹槽对准收纳支架卡扣，使得主机固定在收纳架另一侧，电源线可缠绕在金属管上下两个绕线钩位置。

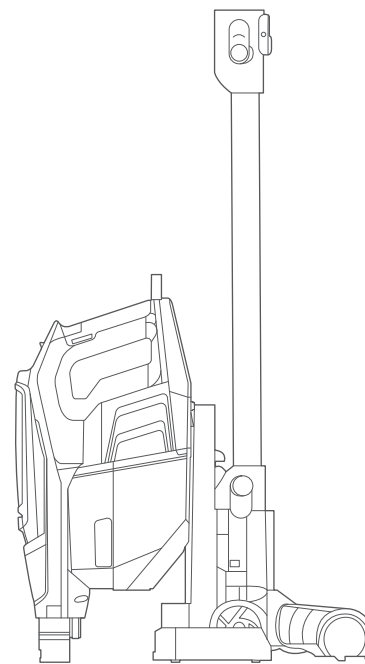

清洁保养

尘杯拆卸与清理

注意

为保持吸尘器吸力，请定期清理灰尘。

按图示取下尘杯组件，再通过金属拉环取下尘杯上盖倾倒灰尘。

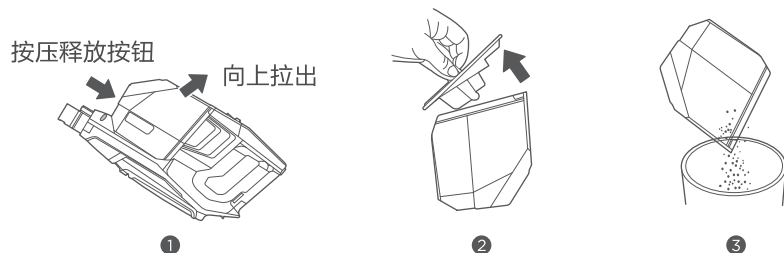

过滤器拆解及清理

注意

1. 过滤棉为可水洗件；
2. 请确认清扫后安装回组件前务必保证每个零件均已晾干。

1. 推动手持机顶部上盖释放按钮，打开上盖；
2. 向上拿出两块过滤棉，抖掉表层灰尘，用水冲洗后阳光下晾晒24h；
3. 过滤棉晾干后重新装回机器，装回上盖。



清洁保养

电动地刷拆解及清理

注意

1. 为避免影响电动地刷运转，当滚刷、轮子被缠绕或脏污时，请进行清洁保养；
2. 拆解保养时，请务必停止电动地刷运转。

1. 缠绕毛发可用剪刀或者刀片清理，详情如图所示；

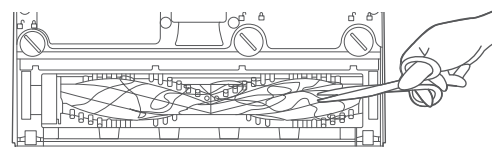

2. 对于不容易清理的碎屑，可以使用一字螺丝刀或者硬币旋转旋钮至开锁位置，打开地刷底板进行清理，详情如图所示；

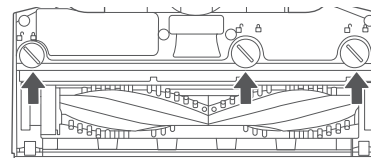

3. 清理完成后重新安装地刷底板，将地刷底板一端卡扣插入地刷孔位，将地刷底板另一端压入配合孔中，旋转按钮至锁紧位置完成安装；详情如图所示。

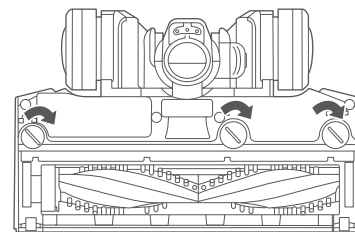

零部件名称	中国RoHS管控物质或元素					
	铅	汞	镉	六价铬	多溴联苯	多溴二苯醚
下盖组件	○	○	○	○	○	○
上盖组件	○	○	○	○	○	○
手柄	○	○	○	○	○	○
电机组件	○	○	○	○	○	○
尘杯组件	○	○	○	○	○	○
延长管	○	○	○	○	○	○
电动地刷	○	○	○	○	○	○
附件	○	○	○	○	○	○
电子电路	○	○	○	○	○	○

备注：

1. 本表格依据SJ/T 11364的规定编制。
2. ○：表示该有害物质在该部件所有均质材料中的含量均在GB/T 26572规定的限量要求以下。
3. ×：表示该有害物质至少在该部件的某一均质材料中的含量超出GB/T 26572规定的限量要求。
4. 本表中的有×的所有部件均符合欧盟的RoHS指令，即“欧洲议会和理事会关于在电子电气设备中限制使用某些有害物质的第2011/65/EU号指令”及其修正案。

产品参数

产品技术参数

型号	额定电压	额定频率	额定功率
V19P11A510CN	220 V ~	50Hz	450 W

- 请勿将吸尘器接近热源，辐射或者燃烧的烟头，严禁吸入下列物体：
 1. 水及溶剂等一切液体；
 2. 石灰、水泥灰等建筑粉尘及垃圾；
 3. 发热物体，如未熄灭碳头、烟头；
 4. 锐利碎片，如玻璃等；
 5. 易燃易爆物品，如汽油或酒精制品。
- 严禁在没有专人的指导下，儿童、弱障或缺乏家电产品使用常识和经验的人使用本产品！
- 您的吸尘器是一台电动器具：它必须按照正常使用条件进行使用，切莫让吸尘器在无人看管情况下独自运转。
- 只有授权的技术人员方可拆解本产品，严禁自行拆解本产品。
- 本产品为室内家用产品，请勿在户外使用。
- 双手潮湿时请勿接触电源线或插座。
- 尘杯已满时请先清空再使用本产品。
- 清洁、维修或暂时不用吸尘器时，必须切断电源。
- 切断电源：不可拉电源线，应用手握住插头塑料部位拨下插头。
- 检查确认供电电压必须与吸尘器使用电压一致。
- 吸尘器的电源线，不要让它穿越锋利的物品，以免损坏电源线。
- 切忌将吸尘器浸入水中，避免接近发热器具或暴晒，以免发生火灾。
- 切勿拖拉电源线来移动吸尘器。
- 下列情形时，请不要使用吸尘器，并及时送至本公司指定的维修部检修：
 1. 发生跌落并出现明显损坏或运转不正常；
 2. 电源线破损。
- 避免在吸入口堵住的状态下长时间运行，以免电机损坏及吸尘器发热变形。

■ 保修须知



注意

1. 本产品只限于家用，非家用出现任何问题本公司概不负责；
2. 如您发现产品需要服务时，请关注微信公众号：eureka优瑞家，获取相应服务信息。

Eureka真空吸尘器严格遵照国家“新三包”规定进行保修服务。
用户在正常使用产品的情况下，提供相关免费维修服务。

- 家庭整机保修两年，电机保修三年。
- 非家庭整机及其主要部件保修半年。
如：经营、商用、公司集体的产品。
- 保修期内用户可享受免费上门维修（特殊地区除外）服务。
“免费上门维修”限桶吸产品。
- 保修期界定：
 1. 以有效保修凭证的开具日期作为保修期的起始日期；
 2. 没有有效保修凭证的，按出厂日期后6个月作为保修期的起始日期；
 3. 若既无有效保修凭证也无出厂日期的，则按该产品的最早上市日期后6个月作为保修期的起始日期；
 4. 网购产品15天界定期以收货日期计算，后期保修可按发票日期计算。
- 保修期内维修更换的零部件归本公司所有，保修期外维修更换的零部件归用户所有。
- 其他事项按照国家“新三包”规定执行。
- 凡属下述情况之一的，不在保修范围内：
 1. 吸尘器附件（金属伸缩管/塑料接插管、软管、地刷、小附件等），耗材（滤芯、集尘袋等）和赠品；
 2. 用户搬运、使用、维护、保管不当而损坏的；
 3. 使用电压低于187 V 或者高于240 V 而损坏的；
 4. 未按产品使用说明书要求使用、维护、保养而造成损坏的；
 5. 非本公司专业服务人员拆卸、维修的；
 6. 因不可抗力（如雷电、火灾、地震、水灾等自然灾害）造成损坏的；
 7. 产品超出保修期的；
 8. 发票或保修卡上记录的型号或编号与商品实物不符合的。
- 以上情况我公司将实施收费维修，费用类型包括维修费、零部件费，具体费用标准在相关部门允许范围内。
- 由代理商、经销商、零售商自行承诺的额外服务与附加的非原厂配置赠品，由原代理商、经销商、零售商负责服务。

■ 保修卡



注意

1. 此保修卡在购买本公司产品时立即填写；
2. 此保修卡请妥善保管，购买者不必将卡寄回本公司；
3. 维修时请携带此证及有效发票正本。

保修卡

用户姓名

电话

通讯地址(邮编)

购买商店

维修点

编号

发票号码

购买时间

维修记录

日期

故障内容

产品型号

处理内容

维修单位名称

电话

维修员签名

提示：修理时需出具发票。

江苏美的清洁电器股份有限公司

地址：苏州市相城经济开发区漕湖大道39号

编码：215000

版本号：V19P11A510CN10-06-R1.1

物料编码：16175000005942

执行标准：GB4706.7-2014/GB4706.1-2005/GB4343.1-2018/GB17625.1-2012



微信扫一扫，服务立马到